



Tools for Rebels





**We love innovations.
We love design.
We love rock'n'roll.**

We firmly believe that our tools make the life of our users simpler, safer and more “full of joy”. We are never satisfied with the existing standards.

There are very many screwdriving tools. But contrary to others, we do not feel that tools will ever reach their final stage of development. We are constantly searching for new ideas.

We think differently. We question. And in this process develop screwdriving tools such as the Zyklop ratchet or the Joker wrench – innovations that are real gamechangers.

You would like to learn more about screwdriving tools?

We are available for you worldwide and the right tool for you can surely be found from among the more than 3,000 different articles we have on offer. 750 Wera Tool Rebels really enjoy reinventing screwdriving tools every day and on working on your problem solvers.

Yet for all this fun, we are still very successful. Our rate of complaints is more or less zero. We are delighted about the many accolades from our customers and are proud of our design awards.

Who are the Tool Rebels?

The expression Tool Rebel (from the Latin rebellis, “rebellious”) refers to someone that goes unusual ways and reinvents tools so to speak. Someone that is not satisfied with established standards and who likes to question the prevailing status quo.

The term first emerges when the screwdriving tool manufacturer Wera asks its customers what they think about the company. Many customers refer to Wera staff as Tool Rebels because they puzzle out unusual problem solutions, are always in a good frame of mind and love rock'n'roll. The Tool Rebels have even found a way of portraying themselves on photos and images with very specific greetings and gestures.

The “Tool Rebel Gang” knows no limits. Meanwhile, some customers and users across the world are referring to themselves as Tool Rebels since they love Wera tools and listen to rock music.



[/weratoolrebels](https://www.facebook.com/weratoolrebels)



[/weratoolrebels](https://www.instagram.com/weratoolrebels)

www.toolrebels.de



Ergonomics you can grasp.

Find out on the following pages what makes our Kraftform screwdrivers so different.



The Kraftform handle

Genuine rebels were already at work in the year 1968. Even in those days, the product developers were not simply content with accepting that frequent screwdriving resulted in calluses on the hands, that insufficient power could be transferred and that slipping away from the screw head was a common problem.

The Kraftform handle was created on the basis of the human hand. The handle features a multi-component design with soft zones for firm gripping and greater torque transfer as well as soft zones for rapid working speeds.

It has been optimised through the years with new technologies, but has kept its proven shape. After all, the human hand has not changed either.

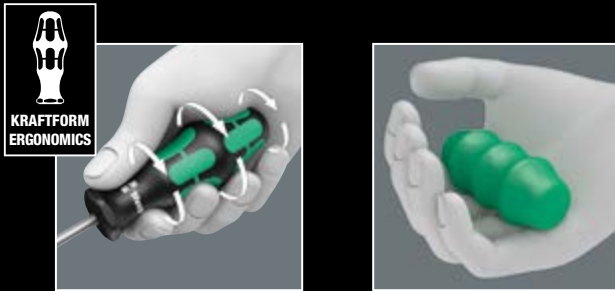

Lasertip

We would like to make life for our users simpler and safer. But work should also be enjoyable and provide for some fun. However, when you slip out of the screw head and perhaps even leave some scratches on the surface, this is anything but funny. That is something we wanted to change.

A precisely-focused laser creates a sharp-edged surface structure. Wera Lasertip "bites" itself into the screw head and prevents any slips out of the recess. It is available for screwdrivers for slotted, Phillips and Pozidriv screws.

Wera Lasertip reduces the contact pressure required and enhances force transfer – meaning less screwdriving effort is required. Screwdriving becomes safer and easier.

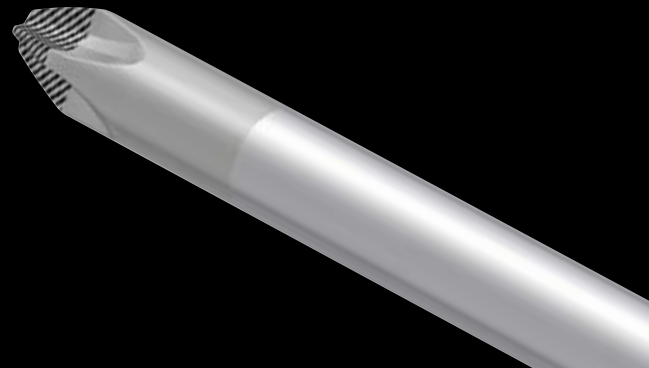

Kraftform Plus VDE

We want our users to be able to work safely and conveniently. So we have now transferred the advantages of the Kraftform Plus technology into the VDE segment.

The individual testing in a water bath at 10,000 volts, in accordance with IEC 60900, ensures safe working with loads up to 1,000 volts.

Impact strength tested at -40°C , guaranteeing safety even under extreme conditions.

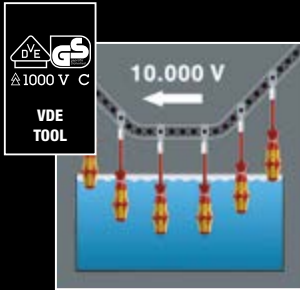

Series 100 iS VDE

Reduced blade diameter with integrated protective insulation, allows sunken screws and spring elements to be accessed and actuated, individually tested as per IEC 60900.

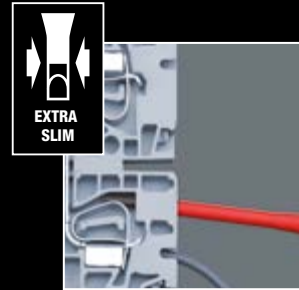

The Chiseldriver

Naturally, a screwdriver is sometimes pushed to its very limits. Conventional screwdrivers often get damaged then. We wanted to find a solution for such special cases.

The chiseldriver is for fastening, chiselling and loosening seized screws. An integrated impact cap and a pound-thru hexagon blade ensure full transfer of force, even when struck with a hammer. The ductile tempered material prevents the blade from splintering or breaking. Greater torque can be transferred by fitting an open-jaw or ring spanner over the integrated hex bolster.



Krafftform Micro

Screwdriving jobs in electrical and precision engineering applications are often tedious and time-consuming. We learned from users what is important for them: working speeds, torque, precision – and we then focused particularly on these issues.

The precision zone directly above the blade gives the user a better feel for the right rotation angle during fine adjustment work. The power zone has integrated soft zones near the blade tip to ensure high torque transfer for loosening or tightening screws without losing contact with the screw. The fast-turning zone just below the rotating cap allow rapid twisting.

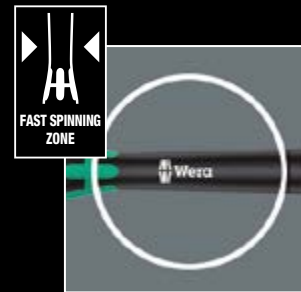
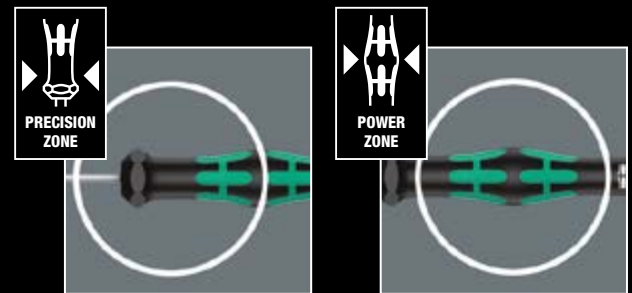

Why are stainless elements so often affected by rust?

One reason: screwdriving jobs are often carried out with a tool made of conventional steel which can result in extraneous rust forming.



This is annoying. We were confident that this could be prevented by using tools likewise out of stainless steel and meeting the required standard of industrial hardness.

A tool series out of stainless steel. The forming of extraneous rust is prevented and a special vacuum ice-hardening process ensures the required degree of hardness.





Take it Easy Tool Finder.

The product developers at Wera love questioning supposedly set standards. The target: to make life for users simpler, safer and “full of joy”. The new Wera “Take it easy” Tool Finder makes it extremely simple to find the right tool.

Coloured sleeves according to profile simply the search for the right drive. The size stamp provides for easy differentiation within the profile. The Wera Tool Finder is available from Wera for all top bit lines: Impaktor, Stainless, Diamond, BiTorsion. Moreover, there are also L-keys, sockets, bit sockets and open-end wrenches available with “Take it easy” Tool Finder.



Manufactured for heavy-duty, applications.

We were not too happy that disintegrating bits flew around users faces as screwdriving with power tools took place with ever-higher power outputs.



We scrutinised the geometry and material properties of the bits for every screw profile. We analysed the destroyed bits, holders and screws in detail. The result is the Impaktor system – our entire know-how from bit manufacturing combined in our very best bit series.

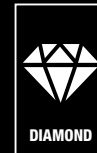

BDC Bits

One of the greatest problems with power tool applications is that the conventional bit easily slips out of the head of the screw (cam-out). This often destroys both the head of the screw and the tool. High resulting costs are incurred e.g. from damaged surfaces and screw connections that can no longer be loosened. Screwdriving will become safer and more economic if this problem of slipping can be minimised.

To solve this fundamental problem, Wera launched a diamond-coated bit on to the market in 1992.

Today, the Wera diamond bit – manufactured with the technology specifically developed by Wera for this application – still sets the standard in terms of resilience and functionality. Wera bits with a diamond coating ensure a secure fit of the bit in the screw head.



The minute diamond particles applied to the tip of the tool literally “bite” into the screw and ensure an exact, anti-slip fit in the head of the screw. This secure fit protects the screw.

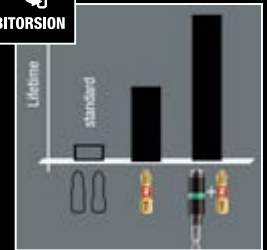

The effectiveness of the BiTorsion system comes from a combination of two shock-absorbing spring elements. Both bits as well as holders have a cushioning torsion zone that diverts the kinetic energy away from the drive tip during peak loads.

The Rapidaptor

We were not happy that bit change with bit holders was often quite cumbersome. We found out that strong magnets or retaining rings indeed hold the bit securely, but they greatly impede removal from the holder. So we have developed bit holders that indeed reliably hold the bit, yet still allow for fast and trouble-free bit change.

The solution: bit holders with quick-release mechanisms that lift the bit from the magnets. Bit holders which – depending on the requirements – additionally have elastic zones that absorb peak loads. Or rapid-spin sleeves with which the cordless or electric screwdrivers can be guided during the screwdriving process.



Rapidaptor holder

Rapid bit change without needing any additional tools. One-hand operation with a freely spinning sleeve for simplified guidance of the tool. Also available in a BiTorsion design.

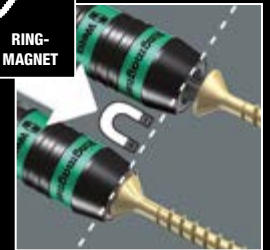

Ringmagnet Rapidaptor

Special design powerful ring magnet, for larger and heavier screws. Ideal for overhead work, too.



Allows hexagon socket screws a longer service life.

We questioned the classic L-key design, since all too often the screw head recess is rounded out, meaning screws can no longer be tightened or loosened – and so the user finds the L-key slipping out of the recess.

Wera Hex-Plus tools have a larger contact surface in the screw head. The notching effects are reduced and thereby the deformation of the screws is reduced. At the same time, as much as 20 % more torque can be applied.

Additionally, the rubber sleeve provides a pleasant grip, particularly in applications at low temperatures. Colour coding and large stamp enable the desired L-key to be easily located.





Does it all. Better.

When we began to think about open-ended wrenches, we asked ourselves: why does the wrench always have to be flipped over; why does it have an offset design; why does it slip off injuring fingers? The new design of the mouth resulted in a real "Joker" that works even when all other trumps have been played.

The Joker's holding function means that nuts and bolts can be held in the jaw and easily positioned where they are needed.

And the exchangeable, hardened metal gripping plate in the Joker's mouth literally bites itself into the bolt, with its extremely hard tips.

Instead of 60°, the Joker only has a 30° return angle thanks to its unique double-hex design. Along with the Joker's straight neck, this means that flipping the wrench has become a thing of the past.



Zyklop Speed

We just could not believe that it was not possible to make a ratchet work more quickly. Moreover, we did not like the way users had to apply many different types of ratchet to get a job done. We therefore questioned everything that was conventional about ratchets.

The Zyklop Speed ratchet is what has emerged. The flywheel design of the Zyklop Speed ensures high working speeds. And: the Zyklop Speed combines the advantages of 5 types of ratchet in a single tool. Additionally, it can be used as a screwdriver.

The ratchet head pivots freely and can be locked into any position by using the slide switch that is positioned on either side.



SPEED

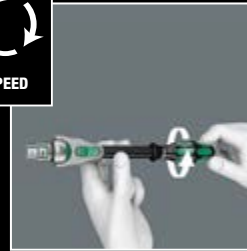

FLEXIBLE
HEAD



SWITCH



5°
FINE
TOOTH



Zyklop Metal

Due to the ever-more confined working environment, space is becoming more and more an issue for the application of ratchets. Our product developers therefore intensively occupied themselves with the issue of confined working spaces, and Wera has now solved this problem.

The extremely slim and robust Zyklop Metal ratchet with a long lever was what emerged. When the change in direction needs to be quick, the Zyklop Metal Switch ratchet is the right tool. When the socket must not get lost and a coincidental change of direction has to be avoided at all cost, the Zyklop Metal Push is the correct choice.

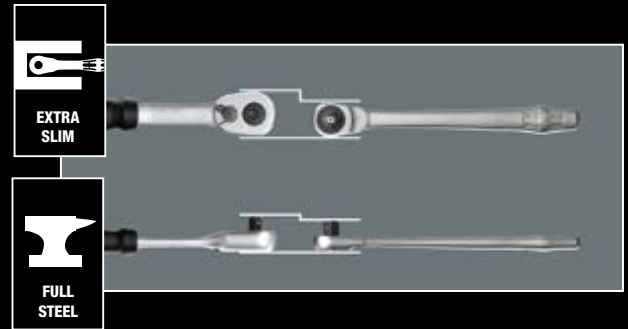

8003 Push



8004 Switch



Zyklus Hybrid

Combines robustness, slim design, and little weight.

We wanted to integrate all the mostly-desired ratchet advantages in a single tool. Our idea was to develop a light ratchet with an ergonomic handle, slim design, long lever and an extension option. Since the term “hybrid” refers to a combination from various sectors, it was quite easy to decide on the name.



Zyklop Mini 1

Combines elegant design with incredible resilience. Suitable for rapid fastening even in confined working situations. The Wera Zyklop Mini is applied whenever fastening with a power tool or conventional tools is impossible due to insufficient space.

The Zyklop Mini 1 for the direct attachment of bit.



Zyklop Mini 2

The Zyklop Mini 2 for the direct attachment of the special Wera Zyklop sockets 8790 FA.

Features a very low height, ideal for confined working spaces.





Obviously, many users also apply their ratchet as a hammer. This often ruins the ratchet and is dangerous to boot.

That is why we developed the heavy-duty Koloss ratchet whose mechanism is extremely robust, and nearly impossible to destroy through impact.

The Koloss is so robust that it can even be used safely with its extension element.



Dual ratchet teeth. Gives the robust 30 saw teeth the precision engineering effect of 60 fine teeth with a 6° return angle.

Changing the ratchet direction using a hardened push-through square drive ensures great resilience, since there is no susceptible switching mechanism that could be damaged by hammer blows. This is far more robust than a forward/reverse switch.

Newly developed, multi-component Kraftform handle that satisfies both the hammer and ratchet application requirements.

The degree of torque applied can be increased by using the Wera extension Koloss 8002 C.

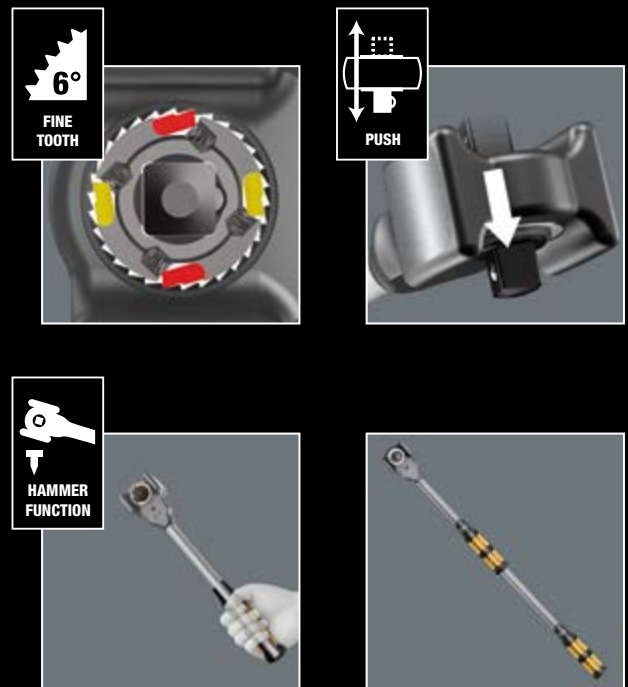

Why is the right tool so often not at hand?

The reason: too many tools and overly-heavy tool bags can make it bothersome to carry them onsite. So for us it was a clear challenge: to design a tool that is suitable for a whole host of applications and can be easily taken along to jobs at other sites.



Our solution: Kraftform Kompakt tools. A handle into which blades with a range of different profiles can be inserted.



Tools with holding function

Many users lose the screw and also their nerve when guiding the tool to the workpiece. We wanted to solve this problem.

The HF tools developed by Wera are ideal because they feature an optimised geometry of the original TORX® profile. The wedging forces resulting from the surface pressure between the drive tip and the screw profile mean that TORX® screws made according to Acument Intellectual Properties specifications are securely held on the tool!

8740 HF

The clamping of the screw is achieved by a flexible locking ball.

8790 HF

The clamping of the screw is achieved by two flexible locking balls and a robust, permanently elastic, heat-shrunk tubing.

367 TORX® HF

967 TORX® HF

867 TORX® HF

8767 TORX® HF

8740 HF

8790 HF



Torque tools

We are fully aware that a screw can be fastened so firmly that it breaks. When a screw has not been fully tightened, it can have disastrous consequences. We wanted to spare our users the experience of having to go through this.

Wera's adjustable torque screwdrivers allow variable torque settings with maximum precision and ensure that the user gets the very best results in the familiar Wera design with superior ergonomics.

With ergonomic Kraftform handle. Distinct audible and perceivable excess load signal when the pre-set torque value is reached.

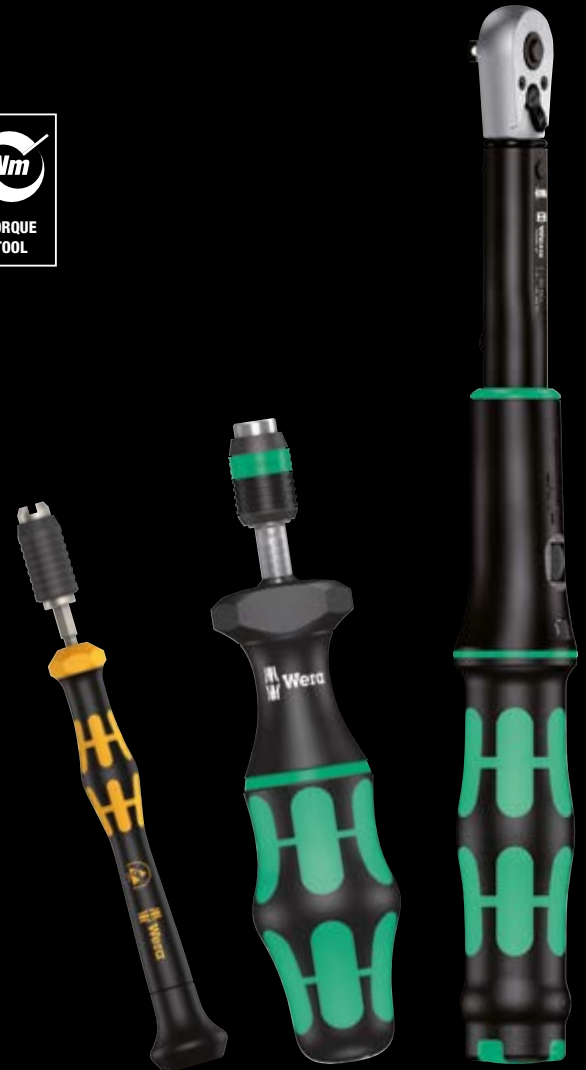



The tool transport system

We wanted to provide our textile boxes and pouches with a mobile home. After all, increasingly more users are more often out and about with their tools and they frequently complain about too much weight. So we started searching for an idea which would keep the hands free during walking and with which one could dock and undock the required tools very easily.



Wera 2go 1 The outside packer!

- Wera 2go Tool Carrier with hook and loop fastener system
- For the docking of the Wera textile boxes and pouches with hook and loop fastener zones
- Individually configurable for greater mobility
- Hands remain free during transport
- Includes an adjustable, detachable shoulder strap with a wide padded section



Wera 2go 2 The outside and inside packer!

- Wera 2go tool container with inner and outer hook and loop fastener zones
- Individually configurable for greater mobility
- Ideal also for the docking of Wera textile boxes and pouches equipped with hook and loop fastener zones
- Easy insertion and removal
- Hands remain free during transport



Wera 2go 3

The inside packer!



- Permanently dimensionally stable thanks to the fabric-lined plastic panels
- High resistance against cuts and stabs
- High protection of the tools transported against damage and moisture
- Can be individually equipped

Which textile boxes can be docked with the Wera 2go system without the need for any additional aids?

Watch out for this symbol:



Wera packaging bearing this symbol contains tool pouches or textile boxes with nonwoven sections that can be docked with the Wera 2go system.

Wera 2go 4

The Tool Quiver!

- Dimensionally stable Wera 2go tool quiver
- High resistance against cuts and stabs
- Variable hook and loop fastener partition for a division into as many as 5 inner sections
- Large set-down area; handle for carrying and hanging up

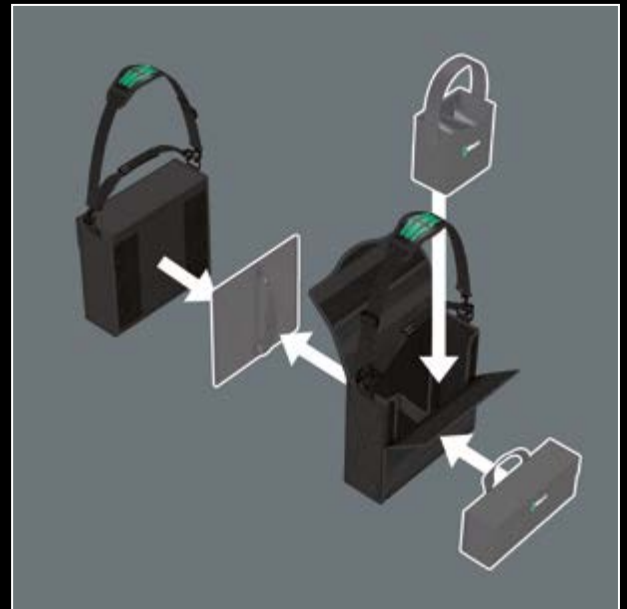

Outstanding boxes and packaging

Previously, ratchets as well as accessories were generally packed in robust but somewhat bulky and occasionally heavy metal cases. The completely new and innovative textile boxes mean there is an undreamt-of improvement in mobility and space requirements. The same number of tools that had formerly to be held with at least one hand on the handle now comes in a compact box which may be a part of your tool case in which many other tools can also be transported.

The repeated running to and fro to move tools from A to B has therefore become a thing of the past. And the much reduced set weight makes carrying far more pleasant than before.

Sensitive surfaces are not damaged when tools are set down and if this were not enough, the textile boxes are also incredibly robust.

The textile box including the tools inside can even escape unscathed when dropped.

Conventional tool packaging out of plastic material is anything but appealing and is not really “full of joy”. We have completely redesigned our tool packaging. But don’t just take our word for it, find it out for yourself!





Want to find out more about
tools for Tool Rebels?

Visit our website: www.wera.de



/weratoolrebels



/weratoolrebels



Wera

Wera Werkzeuge GmbH

Korzter Str. 21-25

42349 Wuppertal

Germany

www.wera.de

Phone: +49 (0)2 02/40 45-0

Fax: +49 (0)2 02/40 36 34

E-Mail: info@wera.de

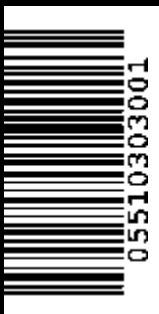

EN 05 510303 001 - 0053701 - 01